



- 总公司——东莞  
Head Office—Dongguan
- 生产基地——东莞、无锡  
Production Base—Dongguan, Wuxi
- 地区性服务中心——印度、土耳其、美国  
Regional Service Centre—India, Turkey, USA
- ★ 销售、服务  
Sales & Service Office
- 研究中心——东莞  
R&D Centre—Dongguan

# DEKUMA

中国高端橡塑机械行业领导者

德国基因, 中国智造

German Technology, Chinese Creation

## 橡胶注射成型机

RUBBER INJECTION MOULDING MACHINE



### 德科摩橡塑科技(东莞)有限公司

DEKUMA RUBBER AND PLASTIC TECHNOLOGY(DONGGUAN)LTD.  
(大同机械有限公司成员 Member of Cosmos Machinery Ltd.)

广东省东莞市东城区周屋工业区银珠路  
Yinzhu Rd, Zhouwu Industrial Park, Dongcheng District,  
Dongguan, Guangdong, China  
Tel: +86-769-22667200 Fax: +86-769-22667227  
E-mail: info@dekuma.com



荣获ISO 9001认证  
An ISO 9001 certified company

Version NO.: DKM-R120 E

### 德科摩橡塑科技(东莞)有限公司

DEKUMA RUBBER AND PLASTIC TECHNOLOGY(DONGGUAN)LTD.  
(大同机械有限公司成员 Member of Cosmos Machinery Ltd.)

# CONTENTS

## 目录

汽配行业  
Automobile Industry

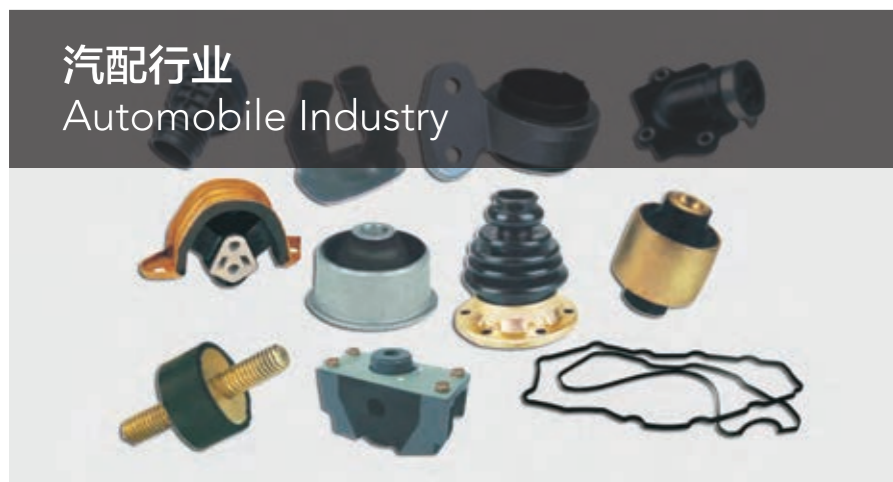

电力行业  
Power Industry



橡胶履带  
Rubber Track



其它行业  
Other Industries



汽配行业 Automobile Industry	P03-10
电力行业 Power Industry	P11-16
模具方案 Mould Solutions	P07-18
橡胶履带机 Rubber Track Production Line	P19-20
轮胎生产线 Press-on Solid Tyre Rubber Production Line	P21-22
液态硅橡胶制品 Liquid Silicone Rubber Product	P23-24
客户方案 Solutions For Customers	P25-26
控制系统 Control system	P27-28
公司简介 Company Profile	P29-30

汽配行业  
Automobile Industry

RV系列/ Series



DKM-RV300

特点 / Characteristics

- 德国技术专家参与优化设计的整个塑化系统，其螺杆可适应各种不同胶料，对于超高硬度胶料也有非凡表现。
  - 注射系统采用特殊设计，可快速拆卸注射贮料部分，易于更换密封环和清理胶料。
  - 进口抗压、耐高温双层隔热板可减少40%的能耗，更可靠，更节能。
  - 合模油缸双重密封，不易漏油。
  - 采用美国高压泵及德国液压阀，保证液压系统的稳定可靠。注射行程和锁模行程采用精度为0.05%的无接触式电子尺控制。
- Designing and optimizing of the plasticization system and injection system are leaded by German engineers, the screw can be suitable for various material, excellent performance even for extra high hardness material. Particularly design for injection system can disassemble the accumulator quickly, facilitate to replace the seals and remove the material.
  - Imported double-layer, High pressure and high temperature resistance thermal insulation plates reduce 40% energy consumption, much more energy saving and more reliable.
  - Dual-seal clamping cylinder, avoid oil leakage.
  - Adopt American high pressure pump and German hydraulic valve, ensure the stable and reliable hydraulic system.
  - The injection stroke and clamping stroke adopt the world famous electronic ruler with accuracy of 0.05%.

机器参数 / Machine Specifications

项目 / ITEM	单位Unit	DKM-RV200	DKM-RV300	DKM-RV400	DKM-RV500	DKM-RV1000
注射压力 / Injection Pressure	bar	1750	1750	1750	1750	1750
注射容积 / Injection Volume	cc	2000	3000	4000	5000	6000
锁模力 / Clamping Force	kN	2000	3000	4000	5000	10000
开模行程 / Mould Opening Stroke	mm	480	570	600	760	700
热板间距 / Distance Between Heating Plates	mm	550	640	700	860	1050
最小模厚 / Min.Mould Thickness	mm	70	70	100	100	350
热板尺寸 / Heating Plate Dimension	mm	500 x 550	650 x 650	700 x 700	800 x 800	1300 x 1300
移模行程 / Mould Sliding Stroke	mm	600	650	680	800	1200
系统压力 / System Pressure	bar	225	200	210	220	210
机器重量 / Machine Weight	Ton	6.5	8.5	10	14.5	48
外形尺寸 (长x宽x高) / Machine Dim.(LxWxH)	m	3.7 x 2.2 x 3.7	3.9 x 2.4 x 4.1	3.7 x 2.45 x 4.9	3.7 x 3 x 5.16	4.9 x 4.1 x 5.9
油泵电机功率 / Hydraulic Pump Motor Power	kW	11	15	22	22	37.5
热板加热功率 / Heating Plate Power	kW	14	16	19	20	80
总装机功率 / Total Power	kW	29	35	44	46	140

如有参数变更，恕不另行通知。We reserve the right to change any design and specification without notice.



应用领域

DKM-RV系列橡胶注射机适用于天然橡胶(NR)、丁腈橡胶(NBR)、三元乙丙橡胶(EPDM)、丁基橡胶等原料，经过注射模具成型技术而制造的橡胶制品，广泛应用于汽车工业、电力工业、民用等领域，如用于加工各种橡胶减震器、橡胶气缸垫、密封件、电缆接头、管接头等。

Applications

DKM-RV series are suitable for Natural Rubber(NR), Nitrile Butadiene Rubber(NBR), Ethylene Propylene Diene Monomer(EPDM), Isobutylene Isoprene Rubber, etc. DKM-RVSe series are applicable in automobile, electric power and civil industries, such as rubber vibration absorber cylinder cushions, sealing parts, cable connectors and pipe connectors, etc.

汽配行业  
Automobile Industry

RV-Se 系列/ Series



DKM-RV160Se(TPV)



应用领域

适用于TPV,TPE,改性软PVC等为原料, 经过注射成型而制造的制品, 广泛应用于汽车工业。特别适用于注射量精准, 外形尺寸大的车窗TPV整体玻璃包边。

Application

It is suitable for TPV, TPE, flexible modified PVC and other raw materials manufactured by injection molding, widely used in the autoglass encapsulation of industry, especially suitable for the overall TPV glass edge of large size car window with precise injection volume.

特点 / Features

- **胶料更新快:** 先进先出立式射台、新胶料在储料腔更新快;
- **操作方便:** 下工作台不动、锁模由上模板向下运动, 四柱锁模,受力均匀。操作平台低;
- **高精度:** 伺服电机泵液压控制系统, 注射量精准, 重复注射精度高;
- **节能、低运作成本、低噪音:** 完全根据所需的压力和流量输出, 耗电量只有同等比例压力和比例流量控制能耗的60%。
- **Quick Material Changing:** Equipped with advanced FIFO vertical injection unit and changing injection chamber material can be done within a short period of time.
- **Easy Operation:** fixed lower platen, moveable upper platen with four columns clamping with even force. Low working platform.
- **High precision:** Adopting servo motor pump and hydraulic control system providing precise injection volume, high repeat injection accuracy.
- **Energy saving, low operating cost and noise:** he output of servo system is completely based on the required pressure and flow of the machine, consuming 60% electricity compared with equal proportional pressure and flow control.

250T-400T玻璃包边机参数  
Parameters of 250T-400T injection machine for glass encapsulation

	项目 / ITEM	Unit	DKM-RV250	DKM-RV400B
射胶系统 Injection System	射出压力 injection Pressure	kg/cm <sup>2</sup>	1840	1840
	理论射出容量 Theoretical injection volume	cc	546	546
	射出速率 Injection Rate	cc/s	242	242
	螺杆转速 Screw Speed	rpm	213	213
	射嘴接触力 Nozzle Contact Force	tons	5.3	5.3
锁模系统 Clamping system	锁模力 Clamping Force	ton	250	400
	开模力 Mould Opening Force	ton	19	32
	模板尺寸 Platen dimension	mm	1100*1000	1250*1100
	最小模厚 Min. Mould Thickness	mm	400	400
	开模行程 Mould Opening Stroke	mm	600	600
滑模系统 Mould Sliding System	最大开模距离 Max. Mould Opening Distance	mm	1000	1000
	滑模行程 Mould Sliding Stroke	mm	1000	1000
液压电力系统 hydraulic and electric system	最大液压压力 Max. hydraulic pressure	kg/cm <sup>2</sup>	210	210
	油泵电机功率 Pump Power	kw	46.1	46.1
	电热容量 Electric heating capacity	kw	13.22	13.22
	机器重量 Machine Weight	ton	13	17

汽配行业  
Automobile Industry

Se系列/ Series

Se系列伺服液压控制原理 / Se series hydraulic servo control principle

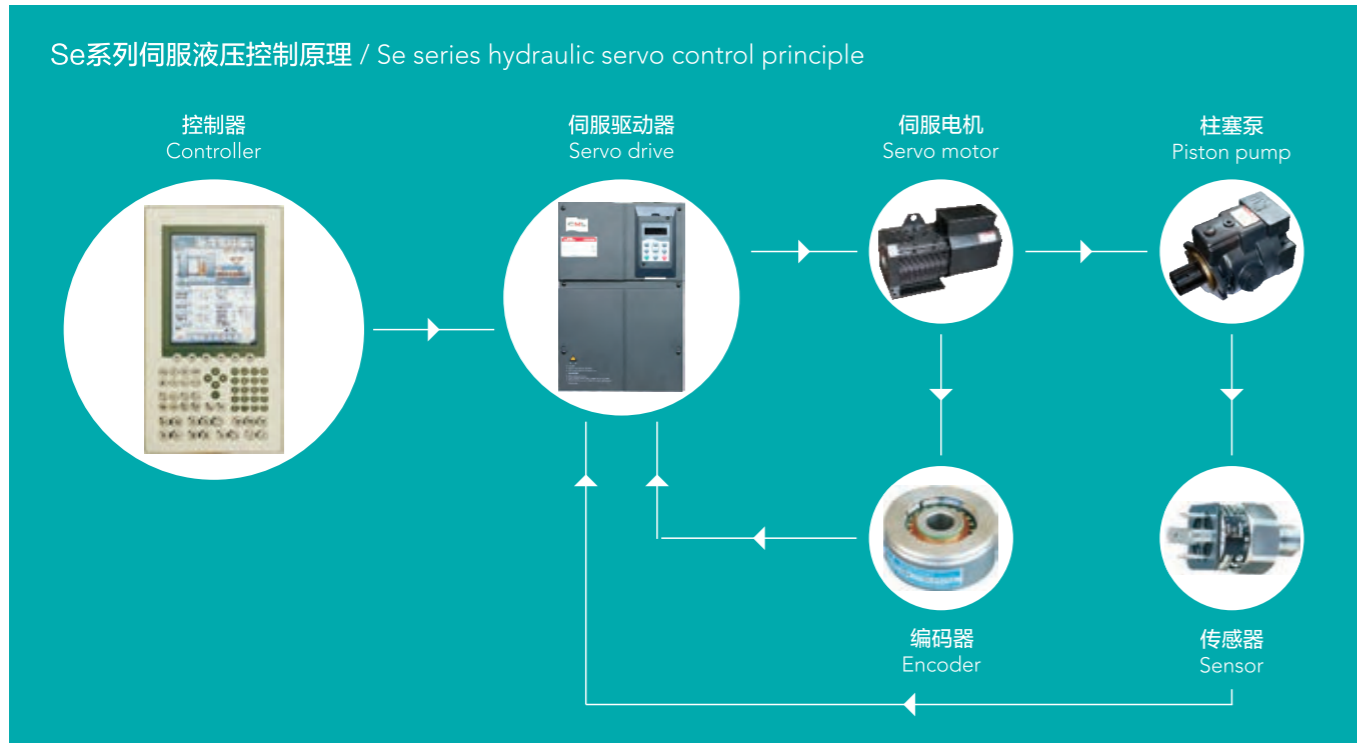

特点 / Characteristics

- **节能、低运作成本**  
伺服系统完全根据所需的压力和流量输出，消除无功能耗，耗电量只有同等比例压力和比例流量控制方式能耗的40%。
- **闭环伺服控制，高重复精度**  
专利Se伺服驱动及控制系统，高精度压力传感器及编码器检测，在工作过程中压力、流量实时比较，控制误差由特定的PID控制器处理，控制精度高。
- **高动态响应**  
高性能伺服专用柱塞泵配伺服同步电机，响应快，减速行程短，提高了速度和稳定性。
- **直观式能耗管理**  
可配电子电能表，实时电能数据通过B&RS98控制系统综合分析及管理。
- **低噪音**  
整机安静运行，即使是在高压锁模和高压注射的情况下，仍然能给您一个安静的工作环境。

- **Energy saving, Low operating cost**  
The output of servo system is completely based on the required pressure and flow of machine, eliminating the reactive energy consumption, only 40% electricity consumption as comparing with equal proportional pressure and proportional flow control method.
- **High repeatability precision**  
Adopting high precision pressure sensor, servo motor, high precision encoder, during operation, the pressure and flow are real time comparison, control error is controlled by specific PID controller.
- **Swift dynamic response**  
High performance pump and synchro servo motor, fast response, short deceleration distance, high speed and stability.
- **Instant power consumption management system**  
Optional electronic wattmeter, instant power consumption data will be processed by B&RS98 controller for machine performance and production analysis.
- **Low noise**  
Creating a quiet environment for you even in the condition of high pressure clamping and injection.

机器参数 / Machine Specifications

项目 / ITEM	单位Unit	DKM-RV200Se	DKM-RV300Se	DKM-RV400Se	DKM-RV500Se
注射压力 / Injection Pressure	bar	1750	1750	1750	1750
注射容积 / Injection Volume	cc	2000	3000	4000	5000
锁模力 / Clamping Force	kN	2000	3000	4000	5000
开模行程 / Mould Opening Stroke	mm	480	570	600	760
热板间距 / Distance Between Heating Plates	mm	550	640	700	860
最小模厚 / Min.Mould Thickness	mm	70	70	100	100
热板尺寸 / Heating Plate Dimension	mm	500 x 550	650 x 650	700 x 700	800 x 800
移模行程 / Mould Sliding Stroke	mm	600	650	680	800
系统压力 / System Pressure	bar	225	200	210	220
机器重量 / Machine Weight	Ton	6.5	8.5	10	14.5
外形尺寸 (长 x 宽 x 高) / Machine Dim.(L x W x H)	m	3.7 x 2.2 x 3.7	3.9 x 2.4 x 4.1	3.7 x 2.45 x 4.9	3.7 x 3 x 5.16
油泵电机功率 / Hydraulic Pump Motor Power	kW	11	16	22	22
热板加热功率 / Heating Plate Power	kW	14	16	19	20
总装机功率 / Total Power	kW	29	35	42	46

如有参数变更，恕不另行通知。We reserve the right to change any design and specification without notice.

DKM-RV200Se

最先进的伺服驱动液压技术带来橡胶加工行业前所未有的优越价值。

Advanced well-proved servo-driven hydraulic technology giving outstanding benefits and values to rubber processors.



汽配行业  
Automobile Industry

Rc系列/ Series



DKM-RC40



DKM-RC25D



应用领域

精密橡胶件，密封条接角，密封件，骨架油封，TPU制品。

Applications

Precise rubber parts, sealing strips, sealing, skeleton oil seal and TPU parts.

特点 / Characteristics

- 采用塑化部分与注射部分完全分开的注射系统。
  - 注射量精确，注射嘴可在硫化时提起。
  - “C”型框架式结构，可以方便三面操作。
  - 可选配双工位。
  - 可选配模压转移功能。
  - 可选配高精度伺服阀控制注射系统
- Adopts plasticizing and injection completely separated, injection system.
  - Precise injection volume, Nozzle can be lifted during vulcanization.
  - The clamping unit with accessible C-frame structure facilitates the operation in 3 side.
  - Optional for double work station.
  - Optional for transfer moulding.
  - Optional for high precise servo valve control injection system.

机器参数 / Machine Specifications

项目 / ITEM	单位 Unit	DKM-RC15		DKM-RC25		DKM-RC25D		DKM-RC40		DKM-RC60		DKM-RC80
		Rubber	TPE	Rubber	TPE	Rubber	TPE	Rubber	TPE	Rubber	TPE	Rubber
注射压力 Injection Pressure	bar	2000	2000/1360 /1000	2000	2000/1360 /1000	2000	2000/1360 /1000	2000	2000/1360 /1000	2000	2000/1360 /1000	2000
注射容积 Injection Volume	cc	62/98 /140	40/70 /125	62/98 /140	40/70 /125	62/98 /140	40/70 /125	62/98 /140	40/70 /125	62/98 /140	40/70 /125	140/250
锁模力 Clamping Force	kN	150	150	250	250	250		400	400	600	600	800
开模行程 Mould Opening Stroke	mm	465	465	500	500	500		500	500	500	500	500
热板间距 Distance Between Heating Plates	mm	500	500	550	560	550		550	560	605	625	600
最小模厚 Min.Mould Thickness	mm	35	85	50	60	50		50	60	105	125	100
热板尺寸 Heating Plate Dimension	mm	400 x 300		400 x 300		400x300		500x 450	550x 450	500x 450	550 x 450	500 x 450
系统压力 System Pressure	bar	250	250	250	250	22.5		250	250	250	250	250
机器重量 Machine Weight	Ton	—		2.5	2.5	4		4	4	4.5	4.5	6
外形尺寸(长 x 宽 x 高) Machine Dim.(L x W x H)	m	—		1.4 x 1.9 x 2.9		2.8 x 2 x 3.35		1.4 x 2.4x 3		1.4 x 1.87 x 3.3		1.4 x 1.5 x 3.6
油泵电机功率 Hydraulic Pump Motor Power	kW	11	11	11	11	11		11	11	11	11	16
热板加热功率 Heating Plate Power	kW	7	—	7	—	10	—	9	—	10	—	7.4
总装机功率 Total Power	kW	21	20	21	20	23		23	22	24	23	30

如有参数变更，恕不另行通知。We reserve the right to change any design and specification without notice.

电力行业  
Electricity Power Industry

RA系列/ Series



DKM-RA500

特点 / Characteristics

- 专为高电压绝缘子设计的机型。
  - 由德国技术顾问参与优化的整个塑化、注射系统，其螺杆具有较大的
  - 输送能力、合理的均化能力以及良好的排气效果。
  - 进口抗压、耐高温双层隔热板可减少40%的能耗，更可靠，更节能。
  - 采用美国高压泵及德国液压阀，保证液压系统的稳定可靠。
  - 奥地利B&R控制系统, 10.4" 液晶彩色显示屏。
  - 注射行程和锁模行程采用精度为0.05%的无接触式电子尺控制。
- Machine designed particularly for high voltage composite insulators.
  - Designing and optimizing of the plasticization system and injection system are leaded by German engineers, enable the screw better delivering capacity, more reasonable homogenization ability and degassing performance.
  - Imported double-layer pressure and high temperature resistance thermal insulation plates reduce 40% energy consumption, much more energy saving and more reliable.
  - Adopt American high pressure pump and German hydraulic valve, ensure the stable and reliable hydraulic system.
  - Austria B&R control system, 10.4" TFT color screen.
  - Imported non-contact linear transducer to control the clamping stroke and injection stroke, with theoretical precision 0.05%.

机器参数 / Machine Specifications

项目 / ITEM	单位 Unit	绝缘子设备 / RIMM for Rod Insulator				套管设备 / RIMM for Hollow Insulator			
		DKM-RA300	DKM-RA500	DKM-RA1000	DKM-RA1500	DKM-RA650	DKM-RA1000	DKM-RA1600	DKM-RA1600
注射压力 Injection Pressure	bar	1120/1350	1200/1480	1200	1420	1200	1200	1200	1200
注射容积 Injection Volume	cc	5000/4000	13000/10000	25000	40000	18000	25000	25000 x 2	50000 x 2
锁模力 Clamping Force	kN	3000	5000	12000	15000	6500	10000	16000	24000
开模行程 Mould Opening Stroke	mm	570	500	700	700	700	800	1000	1200
热板间距 Distance Between Heating Plates	mm	780	780	1050	1050	1200	1160	1500	2000
最小模厚 Min.Mould Thickness	mm	210	280	350	350	500	360	500	800
热板尺寸 Heating Plate Dimension	mm	600 x 1000	630 x 1600	800 x 2700	800 x 3700	800 x 1600	1000 x 1800	1000 x 2600	1500 x 3000
系统压力 System Pressure	bar	200	220	210	210	210	200	210	210
机器重量 Machine Weight	Ton	10	19	49	65	24	45	95	160
外形尺寸 (长 x 宽 x 高) Machine Dim.(L x W x H)	m	4.3 x 1.9 x 3.3	5.65 x 3 x 3.8	6.7 x 4.8 x 4	8.7 x 8 x 4	5.7 x 2.8 x 3.95	6.9 x 5.2 x 4.5	8.1 x 7.5 x 5.1	8.6 x 9 x 5.6
油泵电机功率 Hydraulic Pump Motor Power	kW	15	22	34	64	31	41	68	105
热板加热功率 Heating Plate Power	kW	25	36	90	133	60	80	120	180
总装机功率 Total Power	kW	45	67	140	212	110	150	220	320

如有参数变更，恕不另行通知。We reserve the right to change any design and specification without notice.

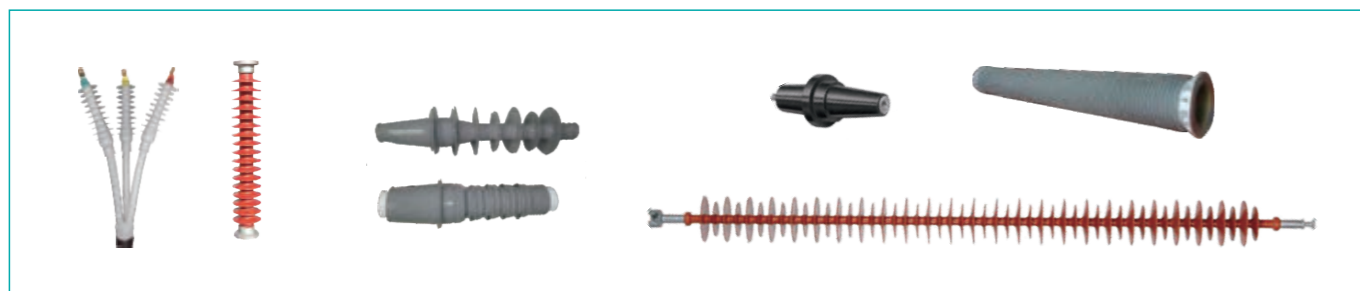

应用领域

适用于硅橡胶、三元乙丙橡胶为原料生产的空心套管绝缘子、棒式绝缘子、避雷器、电缆附件、开关装置。

Applications

Suitable for Silicon Rubber, Ethylene Propylene Diene Monomer (EPDM) to produce hollow core insulator, long rodinsulator, surge arrester, cable accessories, switch gear.

电力行业  
Electricity Power Industry

RT系列/ Series



DKM-RT560



应用领域

适用于固态硅橡胶为原料生产的高压棒式绝缘子、空心套管、避雷器、电缆附件、开关装置。

Applications

Suitable for HTV silicone rubber to produce long-rod insulators, hollow core bushings, arresters, cable accessories and switch gear.

特点 / Characteristics

- 专为高压绝缘子设计的机型。
- 上开合模式结构，大大降低操作高度，操作方便舒适。
- 锁模机构设计安全合理，卡块式锁模，使重心始终在机器锁模结构的几何中心，保证机器运作平稳可靠；开模到位时，锁卡自动卡上保护，做到机械、液压、电器3层保护。
- 采用液压调节模厚，调模方便，在换不同模厚的模具时，方便精准快捷。
- 由德国技术顾问参与优化的整个塑化、注射系统，使其螺杆具有较大的输送能力、合理的均化能力以及良好的排气效果。
- 德国进口耐高温双层隔热板可减少40%的能耗损失，更可靠节能。
- 奥地利B&R控制系统，10.4寸液晶彩色显示屏，操作简易，更人性化。
- Machine designed particularly for high-voltage composite insulators.
- The upper mold open structure, largely reduce operation height, more convenient and user-friendly for operation.
- The designing of clamping unit is reasonable and secure, adopting Block-type clamping style to keep the gravity on the clamping center which ensure the machine work stably. While opening the mould to limitation, the Block will be immediately closed automatically, which ensure to protect the machine mechanical, hydraulic and electrical parts effectively.
- Adopting hydraulic block to adjust mould height during exchanging different moulds, easier quicker, and more accurate operation.
- The designing and optimizing of the plasticization system and injection system are leaded by German engineers, enable the screw with a better delivering capacity, more reasonable homogenization ability and better venting performance.
- Germany imported double-layer high temperature resistance thermal insulation plates reduce by 40% energy consumption, more reliable and more energy-saving.
- Austria B&R controller system, 10.4" TFT color screen, easier for operation, more user-friendly.

机器参数 / Machine Specifications

项目 / ITEM	单位 Unit	绝缘子成型机 RIMM for Rod Insulator		套管成型机 RIMM for Hollow Core Insulator
		RT560	RT1100A	RT1200B
注射压力 / Injection Pressure	bar	1200	1200	1200
注射容积 / Injection Volume	cc	13000	25000	40000
螺杆直径 / Screw Dia.	mm	65	90	90
锁模力 / Clamping Force	kN	5600	11000	12000
开模行程 / Mould Opening Stroke	mm	700	800	1600
热板间距 / Distance Between Heating Plates	mm	940	1080	2200
最小模厚 / Min.Mould Thickness	mm	280	280	600
热板尺寸 / Heating Plate Dimension	mm	1600 x 630	2700 x 800	2000 x 1500
系统压力 / System Pressure	bar	210	210	210
机器重量 / Machine Weight	Ton	20	49	70
外形尺寸 (长 x 宽 x 高) / Machine Dim.(L x W x H)	m	5.65 x 3 x 3.8	6.9 x 4.3 x 3.9	11.8 x 6.3 x 7.4
油泵电机功率 / Hydraulic Pump Motor Power	kW	22	37+ 4	37+ 4
热板加热功率 / Heating Plate Power	kW	36	90	120
总装机功率 / Total Power	kW	68	146	176

如有参数变更，恕不另行通知。We reserve the right to change any design and specification without notice.



电力行业  
Electricity Power Industry

RI系列/ Series



DKM-RI300

特点 / Characteristics

- 经济实用型设备，可以三面操作，特别适合做长制品，如绝缘子、避雷器。
  - 油缸直接注压式送料，结构简单，容易操作。
  - 合模油缸双重密封，不易漏油。
  - 全部采用德国液压阀，精度高，寿命长。
  - 西门子控制系统，5.7”显示屏，友好人机界面。
  - 可选配双工位。
- Economical and practical, enable to be operated in 3-side, suitable for long products, such as insulators, arrestors.
  - Directly feeding by hydraulic cylinder, simple structure, easy to operate.
  - Dual-seal clamping cylinder, avoids oil leakage.
  - German hydraulic valves ensure high precision and long lifetime.
  - Siemens control system, user-friendly interface.
  - Double station option.

机器参数 / Machine Specifications

项目 / ITEM	单位 / Unit	DKM-RI200	DKM-RI200FD	DKM-RI300	DKM-RI300FD
注射压力 / Injection Pressure	bar	800	800	800	800
注射容积 / Injection Volume	cc	2000	2000 x 2	4000	3000 x 2
锁模力 / Clamping Force	kN	2000	2000	3000	3000
开模行程 / Mould Opening Stroke	mm	480	480	350	350
热板间距 / Distance Between Heating Plates	mm	600	600	850	850
最小模厚 / Min.Mould Thickness	mm	120	120	200	200
拉杆净距 / Clear Distance Between Columns	mm	590 x 270	590 x 270	710 x 660	710 x 660
热板尺寸 / Heating Plate Dimension	mm	500 x 800	500 x 800	610 x 990	610 x 990
系统压力 / System Pressure	bar	225	225	250	250
机器重量 / Machine Weight	Ton	4.8	6.5	7	12
油泵电机功率 / Hydraulic Pump Motor Power	kW	11	11	11	11
热板加热功率 / Heating Plate Power	kW	14	28	24	48
总装机功率 / Total Power	kW	25	39	35	59

如有参数变更，恕不另行通知。We reserve the right to change any design and specification without notice.

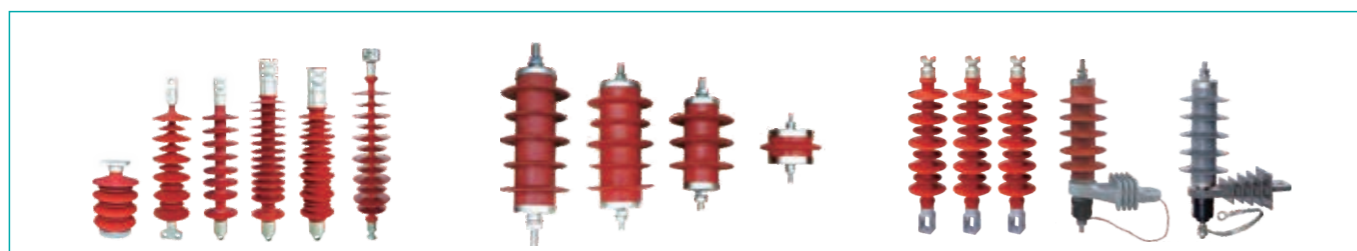

应用领域

普通绝缘子与橡胶制品。

Applications

General insulators and rubber products.

模具方案  
Mould Solutions

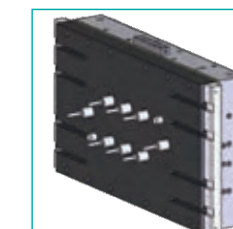
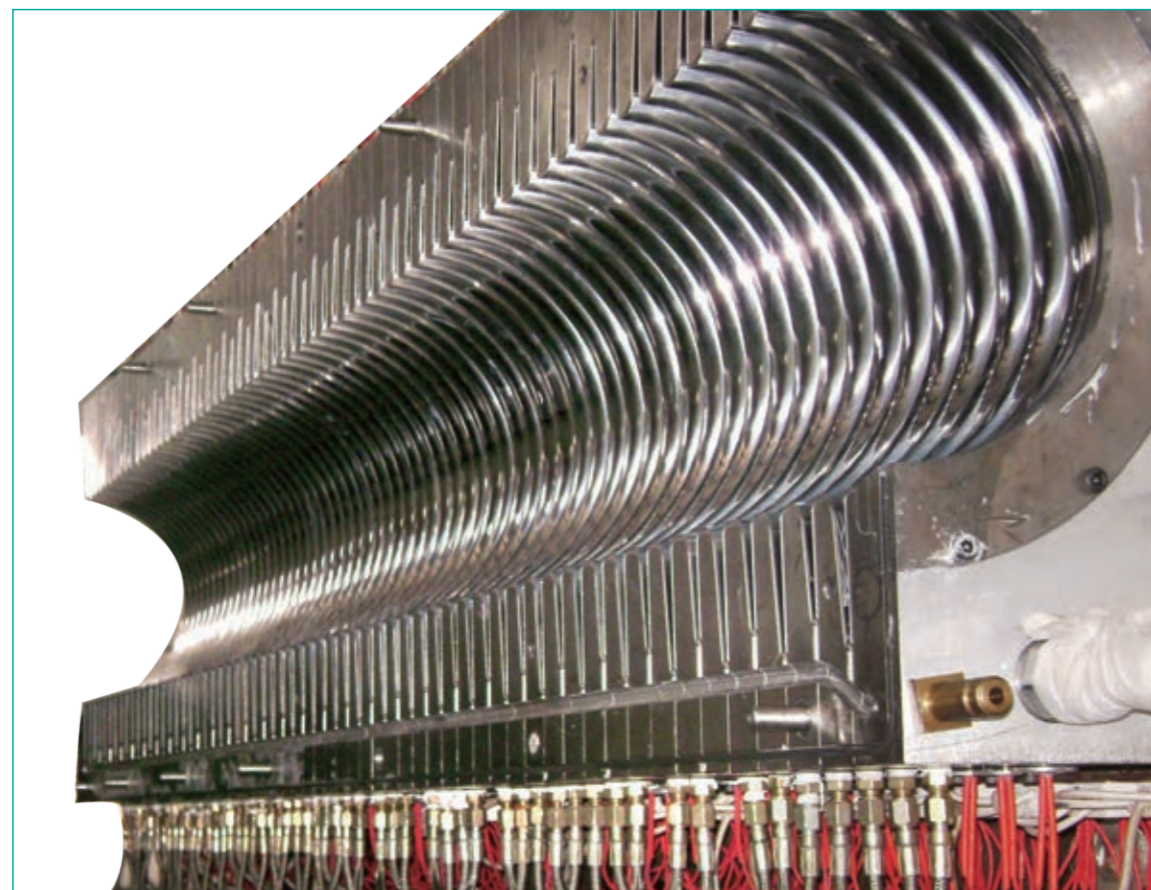

四嘴冷流道 / 4 Nozzles CRB

八嘴冷流道 / 8 Nozzles CRB

空心套管绝缘子方案表 / Hollow Insulator Solution Table

机型 / Machine Model	DKM-RA650		DKM-RA1600			DKM-RA2400	
锁模力 / Clamping Force(T)	650		1600			2400	
绝缘子 / Insulator(KV)	66	110	110	220	330	220/330	550
成型次数 / Moulding Step	1	1	1	1	2	1	2
模腔数 / Mould Cavity	1	1	1	1	1	1	1

如有参数变更，恕不另行通知。We reserve the right to change any design and specification without notice.

棒式绝缘子方案表 / Rod Insulator Solution Table

机型 / Machine Model	DKM-RA300			DKM-RA560 / RT560						DKM-RA1200 / RT1200A				
锁模力 / Clamping Force(T)	300			500						1200				
绝缘子 / Insulator(KV)	11	25/23	66	11	25/23	66	132	220/230	400	500	220/330	400	500	1000
成型次数 / Moulding Step	1	1	1	1	1	1	1	2	3	4	1	2	2	4
模腔数 / Mould Cavity	16	6	2	16	16/8	2	2	2	2	2	2	2	2	2

如有参数变更，恕不另行通知。We reserve the right to change any design and specification without notice.

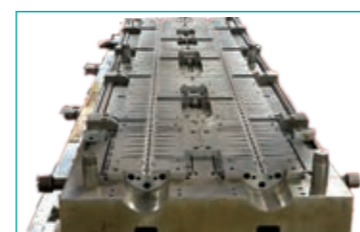
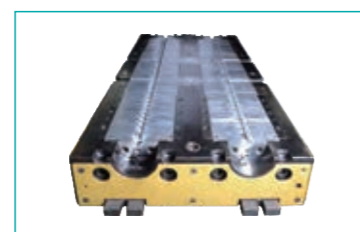
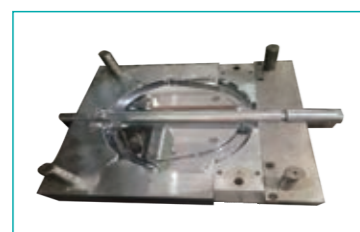

# 橡胶履带机

## Rubber Track Production Line

<p><b>应用领域</b></p> <p>适用于农用车履带、工程车履带、军用车履带、雪地车三角履带等。</p>	<p><b>Applications</b></p> <p>Suitable for agriculture tracks, construction tracks, military tracks and snowmobile tracks.</p>
----------------------------------------------------------	--------------------------------------------------------------------------------------------------------------------------------



DKM-RC280

### 特点 / Characteristics

- 高度自动化：自动上胶片、自动张紧钢带、半自动取出制品。
  - 节能环保：硫化的过程中，将液压泵停掉无动力消耗，而锁模压力无明显下降。
  - 液压精确控制多个动作同步：三台泵的速度从0~100%的速度进行准确的对比调整，实现各动作精确同步。
  - 产品寿命提高：因锁模硫化单元和自动张紧钢带装置巧妙结合，生产的橡胶履带平均使用寿命提高50%。
  - 智能追溯制品质量：智能的控制系统，多种参数的巧妙控制和多工况的监测、控控，生产过程关键参数自动存储。
- High automation: Automatic rubber material loading, Automatic tension steel belt, Semi-automatic taking out product.
  - Energy-saving: Hydraulic pump adjusts the energy consumption during curing to avoiding the energy lost. Clamping force keeps stable during production.
  - Hydraulic precise control multiple actions: the flow of the pumps can be precisely adjusted from 0-100% during the multiple actions.
  - Longer product life: Perfect performance between clamping unit and tension device improves the product life 50% longer.
  - Smart control product quality: Smart control and inspect the performance, data-adjust, data-saving of the machine.

### 机器参数 / Machine Specifications

项目 / ITEM	单位 / Unit	DKM-RC280	DKM-RC480	DKM-RC650
锁模力 / Clamping Force	Ton	280	480	650
热板尺寸 / Heating Plate Dimension	mm	1550 x 640	1960 x 750	1850 x 1050
开模行程 / Mould Opening Stroke	mm	400	400	720
热板间距 / Distance Between Heating Plates	mm	550	550	900
最小模厚 / Min.Mould Thickness	mm	150	150	180
履带最大宽度 / Max.Width of Track	mm	450	550	800
硫化履带规格（长度） / Range of Track	mm	3780-4860	4800-6400	6400-9000
系统压力 / System Pressure	bar	210	210	210

如有参数变更，恕不另行通知。We reserve the right to change any design and specification without notice.

轮胎生产线

Press-on Solid Tyre Rubber Production Line



特点 / Characteristics

整条生产线由以下单元组成

- 橡胶注射机单元
- 多工位平板硫化单元
- 多工位运模自动对接定位单元
- 开模机单元
- 取胎机单元
- 该机组有8个工位，同时可生产8种不同尺寸的轮胎，年产量80000件。

The solid tyre rubber injection line contains the following units

- Rubber injection machine
- Multi-station compression moulding machine
- Multi-station mould conveying auto-docking position unit
- Mould-opening unit
- Tyre unloading unit
- The whole line has 8 working stations, 8 different sizes of tyres can be produced in one line, the yearly output is 80,000 pieces.

机器参数

Machine Specifications

项目 / Item	单位 / Unit	参数 / Parameters
注射压力 Injection Pressure	bar	1380
注射容积 Injection Volume	cc	25000
螺杆直径 Screw Diameter	mm	90
锁模力 Clamping Force	kN	6500
开模行程 Mould Opening Stroke	mm	600
热板间距 Distance Between Heating Plates	mm	600
热板尺寸 Heating Plate Dimension	mm	900 x 820
系统压力 System Pressure	bar	210
机器重量 Machine Weight	Ton	60
外形尺寸 (长 x 宽 x 高) Machine Dim.(L x W x H)	m	17.9 x 5.5 x 5.8
油泵电机功率 Hydraulic Pump Motor Power	kW	37.5
总装机功率 Total Power	kW	65
注射速度 Injection Speed	cc/min	5000

100吨平板硫化机主要参数

100T Flat Vulcanizing Machine

项目 / Item	单位 / Unit	参数 / Parameters
锁模力 Clamping Force	kN	1000
开模行程 Mould Opening Stroke	mm	400
热板间距 Distance Between Heating Plates	mm	500
热板尺寸 Heating Plate Dimension	mm	820 x 820
系统压力 System Pressure	bar	210
油泵电机功率 Hydraulic Pump Motor Power	kW	15

开模、取胎 (上、下) 装置、模具传输装置

Mould-open & Tyre take-out Equipment

项目 / Item	单位 / Unit	参数 / Parameters
卡模最大直径 Snap Gear Max Diameter	mm	800
卡模上下行程 Snap Gear Vertical Stroke	mm	550(cylinder length 600)
取粘上模胎装置卡钢圈直径 Upper Tyre Mould Oro Rim Diameter	mm	150~500
取粘下模胎装置上下行程 Upper Tyre Mould Oro Rim Vertical Stroke	mm	370(cylinder length 400)
取粘下模胎装置卡钢圈直径 Lower Tyre Mould Oro Rim Diameter	mm	150~500
取粘下模胎装置上下行程 Lower Tyre Mould Oro Rim Vertical Stroke	mm	560(cylinder length 600)
送胎 (前后) 行程 Tyre Trans Mitting Stroke	mm	800~900

如有参数变更，恕不另行通知。  
We reserve the right to change any design and specification without notice.

机器参数

Machine Specifications

项目 / Item	单位 / Unit	参数 / Parameters
导轨中心距 Rail Center Distance	mm	603
导轨宽 Rail Width	mm	75
导轨高度 (距地面) Rail Height (From the ground)	mm	680
运模车尺寸 Mould Carrier Dimension	kN	900 x 800
驱动方式 Driving Mode		高频响应比例方向阀 High Frequency Response Proportional Directional Valve



应用领域

实心轮胎 9-22 英寸。

Applications

Diameter range of solid tyre: 9-22 inch.

液态硅橡胶制品  
Liquid Silicone Rubber Product



特点 / Characteristics

- 采用贝加莱S98精明控制系统和世界名牌电器元件，有效控制电气部分小故障,10.4寸彩色显示屏，友好人机界面；
- 具有专利的同步计量装置可连续计量，能适应不同制品对橡胶注射量的要求；
- 进口高质量静态混合器，确保A、B料充分均匀混合。
- S98 smart B&R control system and the world famous brand electrical components, effectively guarantee small fault of the electrical parts; 10.4-inch color display, friendly man-machine interface;
- The patent synchronized dosing device can be continuously measured and able to adapt to the requirements of different products on rubber injection volume;
- Imported high-quality static mixer to ensure an even mixture of material A and B.

机器参数 / Machine Specifications

项目 / Item	单位 / Unit	LSR-V50	LSR-V100	LSR-V200	LSR-H160	LSR-H250	LSR-H400
螺杆直径 Screw Diameter	mm	—	—	—	—	—	—
注射压力 Injection Pressure	cc	125	200	320	—	—	—
理论注射容积 Theoretical Injection Volume	Mpa	120	120	120	—	—	—
注射速率 Injection Rate	cc/sec	166	240	240	—	—	—
射胶行程 Injection Stroke	mm	—	—	—	—	—	—
锁模力 Clamping Force	Ton	50	100	200	160	250	400
模板最大间距 Max.Daylight	mm	500	600	800	1600	1900	2600
锁模行程 Clamping Stroke	bar	300	480	600	1200	1500	2000
四柱间距 Distance Between Tie Bars	mm	440 x 300	705 x 500	920 x 560	—	—	—
容模空间 Mould Space	mm	400 x 400	600 x 600	800 x 800	800 x 1600	1250 x 2000	1500 x 3000
最小模厚 Min.Mould Thickness	mm	200	200	200	400	400	600
顶针力 Ejector Force	Ton	—	—	—	11	15	15
顶针行程 Ejector Stroke	mm	—	—	—	400	400	500
主马达功率 Major Motor Power	kW	11	15	22	15	15	22
系统压力 System Pressure	Mpa	20	20	20	20	20	20
电热功率 Heating Power	kW	6	14	24	—	—	—
机器重量 Net Weight	Ton	4	6	10	—	—	—

如有参数变更，恕不另行通知。We reserve the right to change any design and specification without notice.



应用领域

电子配件、电力绝缘子、避雷器、电缆附件、密封件、婴儿用品、食品器具、厨房用品及体育用品等。

Applications

Electronic components, insulator, arrester, cable accessories, sealings, infant care, food container, kitchen articles and sports industry, etc.

## 客户方案 Solutions For Customers

### 塑化 & 注射系统 / Plasticizing & Injection System

- 由德国技术顾问参与优化的整个塑化、注塑系统。
- 塑化结束前，螺杆减速；可快速拆卸注射柱塞。
- 三个独立可调压力、速度的注射区域；三个可独立调节压和速度的保压区域。
- The plasticizing and injection unit are optimized by German technical consultants.
- Screw speeds down before plasticizing over, injection piston is easy to be disassembled.
- 3 separated injection zones with pressure and speed adjustable, 3 dwell zones with pressure and speed adjustable.

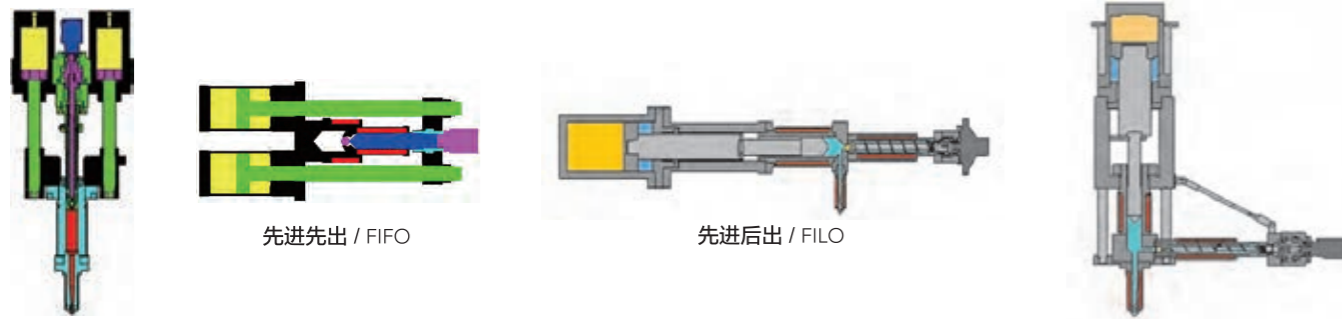

### 锁模系统 / Clamping System

- 主要受力零件采用有限元分析，确保零件刚性大。
- 三个独立可调压力、速度的合模区域；可调节压力的低压保护和高压保护设置。
- 多次排气动作设置，行程精确。
- Finited element stress analysis for all key parts ensures the max. rigidity of the parts.
- 3 separated clamping zones with pressure and speed adjustable; low pressure and high pressure adjustable protection device.
- Multi-degassing motion setting, precise clamping stroke.

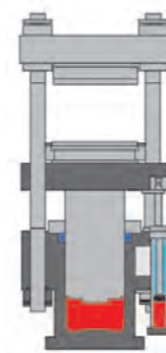

### 电气&液压控制系统 / Electric and Hydraulic Control System

- 采用专业工控电脑和专用软件控制，电器元件全部采用世界名牌产品。
- 采用德国原产比例流量、压力控制阀，方向阀，机器动作平稳，无渗漏，无误动作，使用寿命长，无外渗漏。
- Specialized industrial computer and software control; all electric and electronic components are well-known international brands.
- Original German proportional flow rate valve, pressure valve, and direction valve guarantee the machine with smooth movement, no leakage, no wrong movement, world famous sealing parts, enduring, and without outer leakage.



### 温度控制系统 / Temperature Control System

- 塑化料筒温度与注射料筒温度分别采用各自独立的温油导热系统进行不同温度控制，能确保温度控制精确。
- Separate heat transfer oil system for plasticizing and injection barrel to realize different temperature control and ensure precise temperature control.

## 客户方案 Solutions for customers

设备采用模块化设计，可根据客户不同制品、不同生产工艺需求选配各种设备装置，保障生产效率最大化。

The machine adopts modular design. All kind of options can be selected per customer's different articles and different process needs, which guarantee the max. production efficiency.

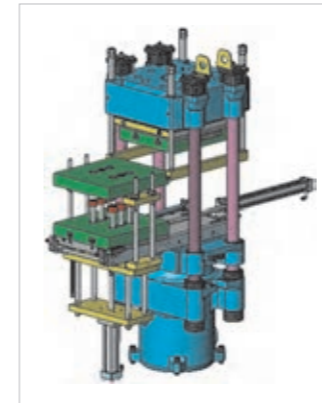

移模单层顶出  
Sliding & Single-layer Ejecting

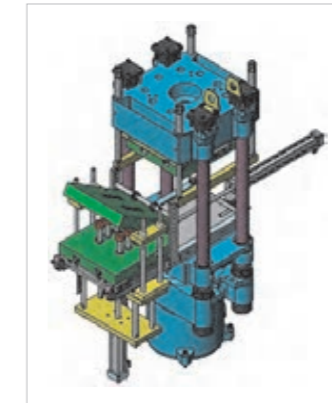

移模单层顶出翻模  
Sliding & Single-layer Ejecting & overturn

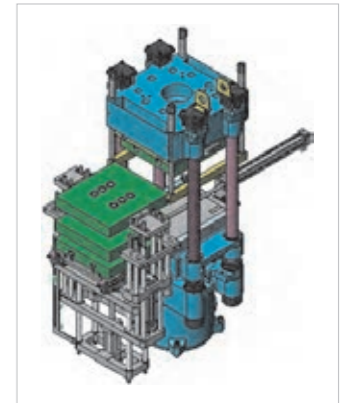

移模双层顶出  
Sliding & Double-layer Ejecting

装置名称 / Device name	RV	RA	RC	RI
机械吊模装置 / Upper Mechanical Mould Lifting Device	●	●	●	●
液压吊模装置 / Upper Hydraulic Mould Lifting Device	●	●	●	●
机械托模装置 / Lower Mechanical Mould Holding Device	●	●	●	●
液压托模装置 / Lower Hydraulic Mould Supporting Device	●	●	●	●
中模移出装置 / Mid Mould Sliding Device	●	●		●
下模移出装置 / Lower Mould Sliding Device	●	●	●	●
单层顶出装置 / Single-layer Ejecting Device	●	●	●	●
双层顶出装置 / Double-layer Ejecting Device	●	●		●
单层上顶出装置 / Single-layer Upper Ejecting Device	●	●	●	●
翻模装置 / Mould Tick-rack Device	●	●		●
硅胶送料装置 / Silicon Rubber Feeding Device	●	●	●	
冷流道装置 / Cold Runner Device	●	●	●	
冷流道用温油控制装置 / Cold Runner With Heat Transfer Oil Device	●	●	●	
全封档门 / All Round Cover	●	●	●	
真空泵 / Vacuum Pump	●	●	●	●
Ce认证 / CE Safety Standards	●	●	●	●

可根据客户制品要求提供非标或专用橡胶成型设备。

Either non-standard or specially designed rubber injection moulding machines can be provided per customer's article requirements.

iSee 智能管理云平台  
iSee Intelligent management cloud platform



iSee的由来 / The Origin of iSee

iSee4.0智能管理云平台，是CML集团自主研发的计算机软件系统。

The ISee4.0 Intelligent Management Cloud System is self-developed by CML group.

主要功能 / Main functions

收集、分析和监控设备数据，从而让经营决策者能随时随地系统全面地了解机器状态，制定精准的生产计划和公司策略。

The machine data will be collected, analysed and monitored, and the company managerial decision maker can apply the accurate production plant and company strategy after fully gaining the machine status anytime anywhere.

适用范围 / Scope of application

适用任何开放接口的机器。

Applicable to any machine of interface access-free.



iSee网络架构图 / iSee Network Structure chart

对于不上云的客户也可在局域网内实现  
It can be implemented in the LAN for the non-cloud customers.

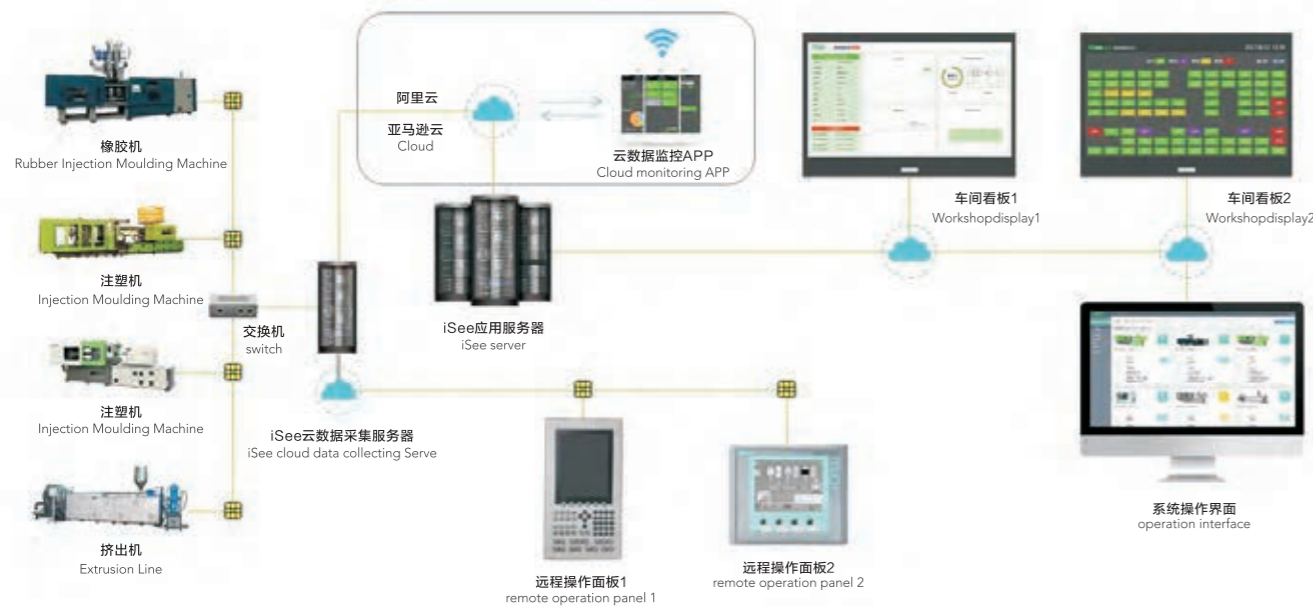

iSee功能模块 / ISee SPC

整体功能  
Overall function



**设备总览 / Equipment Overview**  
显示所有机器：名称、状态、实时数据、生产进度、设备利用率等重要参数  
To display the important data of all machine: machine ID, status, real-time data, production schedule and machine on duty rate etc.

**车间看板 / Workshop Display**  
状态看板、生产看板、综合看板、SPC看板  
status display, production display, general display, SPC display

**生产分析 / Production Analysis**  
显示机器：名称、状态、模具、产品名称、目标量、完成率、预计完成日期、设备利用率等详细参数  
to show the data of machine: Machine ID, status, mould ID, product ID, target quantity, finished rate, expected time to finish, machine on duty rate etc.

**分析报表 / Analysis Report**  
包含：设备SPC比较、设备能耗分析。可对比相同参数的差异，从而改善工艺  
including: machine SPC comparison, machine energy consumption comparison. The production process can be improved after comparing the difference on the same parameter.

**排产管理 / Production Management**  
包含：工单导入、工单分析、生产追溯、生产管理  
including: production order importing, production order analysis, production trace back, production management

iSee的投资效益分析 / Investment Benefit Analysis of iSee

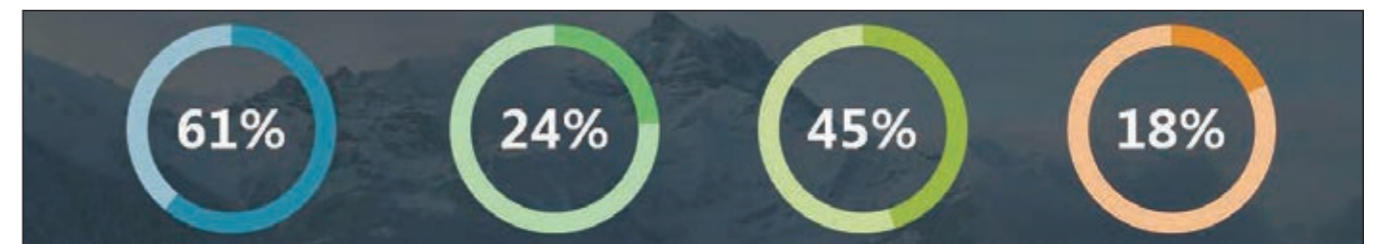

减少交班的纸面工作  
Reduce paper work on shifts

减少半成品  
Reduce semi-finished products

减少制造周期时间  
Reduce manufacturing cycle time

减少产品缺陷  
Reduce product defects

## 公司简介 Company profile



## 中国高端橡塑机械行业领导者 Leading rubber and plastic machinery manufacturer of China

### 全球知名的橡塑科技方案供应商

在全球，德科摩为顾客提供整套橡胶技术及挤出技术的交钥匙方案。成立于2004年，德科摩由大同机械有限公司（香港上市公司大同机械企业有限公司全资子公司）及德国Dekuma GmbH合资成立。多年来始终专注于橡胶注射成型机、管材挤出生产线、液压机的研发、生产、销售。产品广泛应用于汽车零部件、建筑材料、能源输送、电子通讯等领域。以卓越超前的技术及专业快速的服务，本着为客户创造最大价值的使命，并矢志成为世界橡塑设备方案的领先品牌。

### 秉承德国技术标准，产品精益求精

德科摩产品始终秉承德国技术标准，核心部件均由德国工程师主导设计，且所有原材料的选用及加工流程都严格遵循德国标准，从而使德科摩的产品均具有极高的可靠性及稳定性。经过多年的发展和经验的不断积累，德科摩持续深挖行业专用市场，为客户提供行业定制专用设备。产品的技术、质量与服务均明显领先于国内同行，成为替代进口品牌的品质之选。

### Globally Renowned Rubber And Plastics Technology Solution Supplier

Globally, Dekuma offers customers a complete turnkey solution for rubber injection moulding technology and extrusion technology. Found in 2004, Dekuma was a joint-venture between Cosmos Machinery Ltd (a wholly owned subsidiary of the HK publicly listed Cosmos Machinery Enterprises limited) and Germany Dekuma GmbH. For many years, we have been focusing on the development, production and sales of rubber injection moulding machines, pipe extrusion lines and hydraulic presses. Products have been widely used in automotive parts, building materials, energy transportation, telecommunications and other fields. With excellent advanced technology and professional and fast service, we are committed to creating the greatest value for our customers, and we are determined to become the leading brand of rubber and plastic equipment solutions in the world.

### Adhering to German technical standards, constantly perfecting products

Dekuma products always adhere to the Germany technical standards, the core components are designed by German engineers, and all raw materials are selected and processed in strict accordance with German standards, so that Dekoma products have high reliability and stability. After years of development and continuous accumulation of experience, Dekuma continues to dig deep into the industry-specific market to provide customers with customized equipment for the industry. The technology, quality and service of the products are clearly ahead of the Chinese counterparts and become the quality choice for replacing those world famous brands.

## 德国基因，中国智造 Germany technology, Chinese creation

### 产品及服务遍及全球、享誉全球

目前，德科摩已有完善的能满足不同客户需求的各类专家团队，数十项国家专利，并承担多项政府研发公关项目，自2013年起被评为国家高新技术企业。超大型化、高精密、高效、智能化、自动化、专用化是公司各类产品的主要特点及业务发展方向。公司长期与多家国际知名橡塑设备供应商保持良好的合作关系，产品遍布欧美、拉美、中东、东南亚等数十个国家，广泛应用于汽车零部件、建筑材料、能源输送、电子通讯等不同领域，并助力各个行业技术革新及生产工艺的快速发展。我们将紧跟行业趋势与市场变化而不断自我创新，持续为国内外客户提供智能化、自动化、专业化程度更高的整体解决方案，将DKM打造成为值得信赖的世界一流品牌。

### Products and services are spreaded and renowned worldwide

At present, Dekuma has a comprehensive team of experts who can meet the needs of different customers, dozens of national patents, and undertake a number of government R&D public relations projects. Since 2013, it has been rated as a national high-tech enterprise. Ultra-large size, high precision, high efficiency, intelligence, automation and specialization are the main features of the company's various products and business development direction. The company has long maintained good cooperative relations with many internationally renowned rubber and plastic equipment suppliers. It is products are distributed in dozens of countries in Europe, America, Latin America, Middle East and Southeast Asia. It is widely used in auto parts, building materials, energy transportation, telecommunications, etc. The field and the rapid development of technological innovation and production processes in various industries. We will continue to innovate in keeping with industry trends and market changes, and continue to provide intelligent, automated and professional solutions to domestic and foreign customers, and build DKM into a world-class brand that can be trusted.

